

STANDARD CONSTRUCTION
FRAME:

0.032" THICK, ROLL FORMED ALUMINUM (0.045" THICK EXTRUDED ALUMINUM FOR UNITS WITH EITHER WIDTH OR HEIGHT 30" OR LARGER). FRAME IS ASSEMBLED USING CORNER CLIPS TO ASSURE HAIRLINE MITERED CORNERS.

BLADES:

0.030" THICK ROLL FORMED ALUMINUM. 2-WAY DEFLECTION. ADJUSTABLE CURVE BLADE DESIGN

VANES:

DEFLECTION VANES ARE EASILY SET WITHOUT USE OF SPECIAL TOOLS.

DAMPER:

MULTI-SHUTTER DAMPER IS EASILY ADJUSTED.

DEPTH:

NARROW DEPTH OF DAMPER DESIGN ALLOWS GRILL/DAMPER COMBINATION TO BE USED IN STACK HEADS OF MINIMUM DEPTHS.

GASKET:

RUBBER GASKET IN COMPLIANCE WITH FLORIDA STATE BUILDING CODE.

OPTIONAL:

MODEL PF PLASTER FRAMES ARE AVAILABLE.

FINISH:

SKY-WHITE (STANDARD)
MILL FINISH (OPTIONAL)

AXALTA SKY-WHITE 100% POLYESTER POWDER COATING GIVES AN ATTRACTIVE BRIGHT WHITE FINISH AND PROVIDES ADDITIONAL PROTECTION FROM AGING AND WEAR.

SIZES:

4" X 4" MIN
36" X 36" MAX

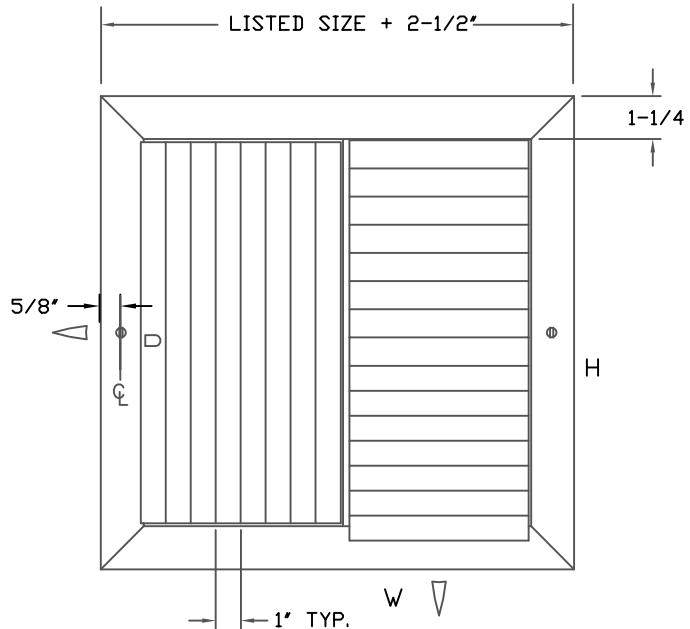
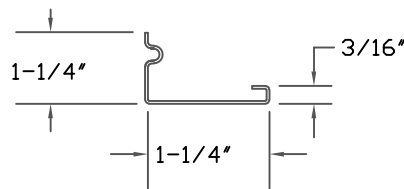
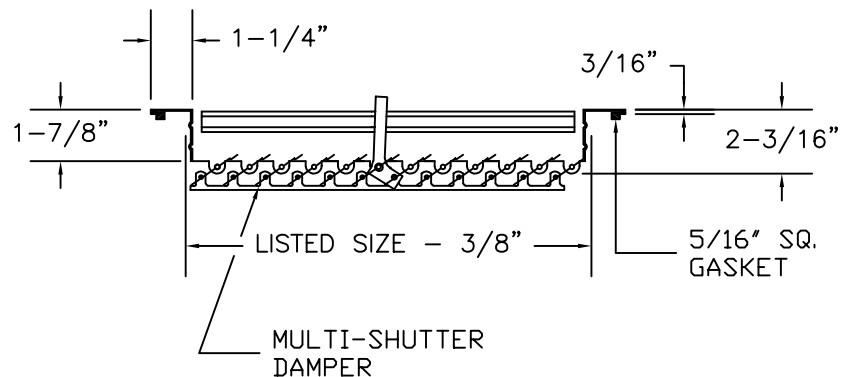
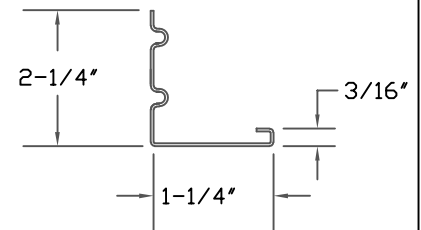
STANDARD FRAME PROFILE

EXTRUDED FRAME PROFILE

JOB NAME:
LOCATION:
ARCHITECT:
ENGINEER:
CONTRACTOR:
CONTACT GRILLE TECH INC. FOR ADDITIONAL INFORMATION OR WITH SPECIAL REQUIREMENTS.
5101 NW 36TH AVE MIAMI, FL 33142 PHONE: 305-537-0053 FAX: 305-537-0064
WEB: WWW.GRILLETECHINC.COM EMAIL: SALES@GRILLETECHINC.COM

MODEL CLCLM

CURVED BLADE LOUVERED FACE
2-WAY CORNER DEFLECTION GRILLE OR REGISTER
WITH MULTI-SHUTTER DAMPER

NOTE: ALL DRAWINGS SUBJECT TO CHANGE WITHOUT PRIOR NOTICE.

DRAWN BY:	MR	DATE:	7/17/17	SCALE:	NOT TO SCALE	DRAWING NO.	CLCLM
CHECKED BY:	IG	DATE:	7/31/17	REVISION:	7/17/17		

CL2, CLCR, CLCL Curved Blade

Neck Vel.	FPM	300	400	500	600	700	800	900	1000
Neck Size	Ps	.040	.040	.110	.160	.220	.290	.360	.440
8 x 4	CFM	55	73	91	109	127	145	163	181
	Throw	5-8	6-10	8-13	10-16	11-19	13-21	14-23	16-26
	NC	<20	23	30	34	39	42	46	49
10 x4 6 x 6	CFM	63	84	105	126	147	168	189	210
	Throw	6-9	7-11	9-14	11-17	12-20	14-22	15-24	16-27
	NC	<20	24	30	35	40	43	47	50
12 x 4 8 x 6	CFM	86	114	143	172	201	230	259	288
	Throw	5-9	7-12	9-15	11-18	12-20	14-23	16-26	17-28
	NC	<20	25	31	37	41	44	47	51
16 x 4 8 x 8	CFM	117	156	195	234	273	312	351	390
	Throw	6-10	8-12	9-15	11-19	13-21	15-24	16-28	18-29
	NC	<20	25	32	37	42	45	48	52
18 x 4 12 x 6	CFM	132	176	220	264	308	352	396	440
	Throw	6-10	8-13	10-17	11-19	14-22	15-25	17-28	19-31
	NC	<20	26	32	37	42	46	49	52
18 x 6 14 x 8	CFM	211	280	351	421	491	561	631	701
	Throw	7-11	9-15	11-18	13-22	15-25	17-29	19-31	21-35
	NC	<20	27	34	39	44	48	52	55
20 x 4 16 x 6	CFM	148	197	246	295	344	392	441	490
	Throw	6-10	9-14	10-17	12-20	14-23	16-26	18-29	20-33
	NC	<20	27	33	38	43	47	49	53
20 x 6	CFM	228	304	380	456	535	608	684	760
	Throw	7-12	9-15	11-19	14-22	15-25	17-29	19-32	22-36
	NC	<20	28	34	39	44	48	52	55
20 x 8 14 x 12 16 x 10	CFM	324	432	540	648	756	864	972	1080
	Throw	8-13	10-16	12-20	14-24	17-28	19-31	21-35	23-36
	NC	21	29	35	41	45	49	53	57
24 x 4 12 x 8	CFM	188	251	314	377	440	503	566	630
	Throw	6-10	9-14	10-17	12-20	14-23	16-26	18-29	20-33
	NC	<20	27	33	39	44	47	51	54
24 x 6 12 x 12	CFM	276	368	460	552	644	736	828	920
	Throw	7-12	9-15	12-20	14-23	16-27	18-30	20-33	22-37
	NC	<20	28	35	41	45	49	52	57
30 x 6 14 x 14	CFM	381	508	635	762	889	1016	1143	1270
	Throw	8-13	11-18	13-21	15-25	17-29	20-32	22-36	25-41
	NC	21	29	36	42	46	51	54	58
30 x 8 18 x 4	CFM	501	668	835	1002	1169	1336	1503	1670
	Throw	9-14	11-18	14-22	16-27	18-30	21-35	24-39	26-43
	NC	22	31	37	43	47	52	56	59
36 x 6 18 x 12	CFM	435	580	725	870	1015	1160	1305	1450
	Throw	8-13	11-18	13-22	15-26	18-29	20-35	22-37	25-42
	NC	22	30	37	42	47	51	55	59
36 x 8 24 x 12	CFM	564	752	940	1128	1316	1504	1692	1880
	Throw	9-15	11-29	14-23	17-27	19-31	22-36	24-40	27-44
	NC								
36 x 10 30 x 12	CFM	711	948	1185	1422	1659	1896	2133	
	Throw	9-15	12-20	15-25	17-29	20-33	22-33	26-43	
	NC	22	32	39	45	49	53	58	
48 x 12 24 x 24	CFM	1152	1536	1920	2304	2688	3072		
	Throw	11-17	14-22	17-27	20-32	22-37	26-43		
	NC	25	33	41	46	51	57		
48 x 24	CFM	2181	2908	3635	4362	5089	5816		
	Throw	12-20	16-26	19-31	23-38	27-45	32-53		
	NC	27	36	44	49	55	60		

Notes:

1. Performance data based on Model CL1DL, blade pattern at 15°.
2. Throw is based on terminal velocities of 100 FPM and 50 FPM respectively.
3. When unit is mounted away from ceiling (i.e. exposed duct), throw is reduced by 15-20% and drop is increased by 5-15%.