

STANDARD CONSTRUCTION

FRAME:
3003H14 ROLLFORMED ALUMINUM
NOMINAL WALL THICKNESS OF 0.032"

BLADES:
3003H14 ROLLFORMED ALUMINUM
NOMINAL WALL THICKNESS OF 0.032"

FINISH:
POLYESTER SKY WHITE POWDER COAT (STANDARD)
SATIN ALUMINUM (OPTIONAL)

GASKET:
SPONGE RUBBER

OPTIONS:
FACTORY INSTALLED OPPOSED BLADE DAMPER
INSECT SCREEN (NOT RECOMMENDED WITH DAMPER)

STANDARD SIZES:
4" X 4" MIN. / 36" X 14" MAX.

FEATURES

HEAVY ROLLFORMED ALUMINUM PROVIDES SUPERIOR DURABILITY AND RESISTS CORROSION.

BLADES ARE TEAR-DROP SHAPED AND ARE SPACED 3/4" ON CENTER. EACH BLADE IS INDIVIDUALLY ADJUSTABLE WITHOUT THE NEED FOR TOOLS.

RUBBER GASKET PREVENTS LEAKAGE AND STREAKING.

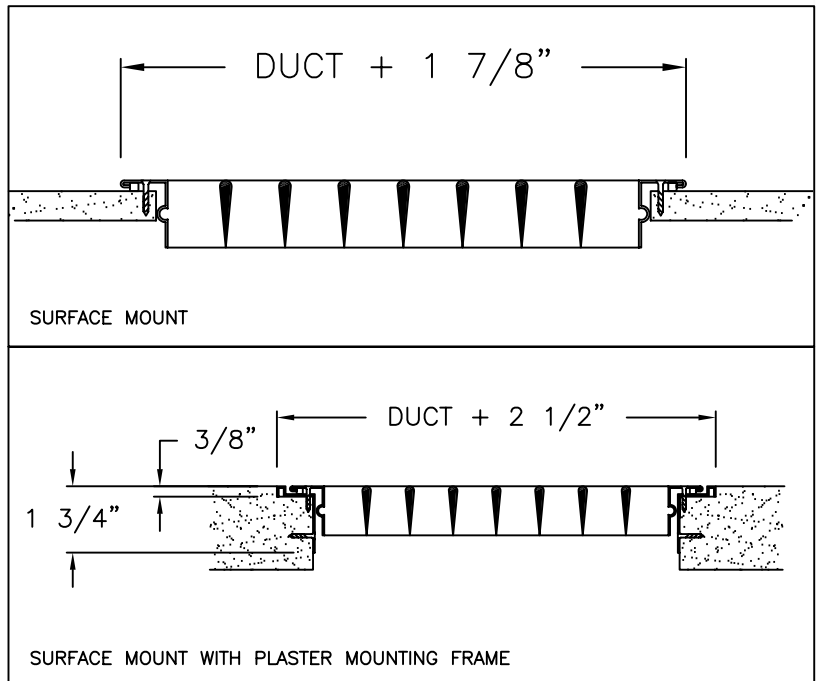
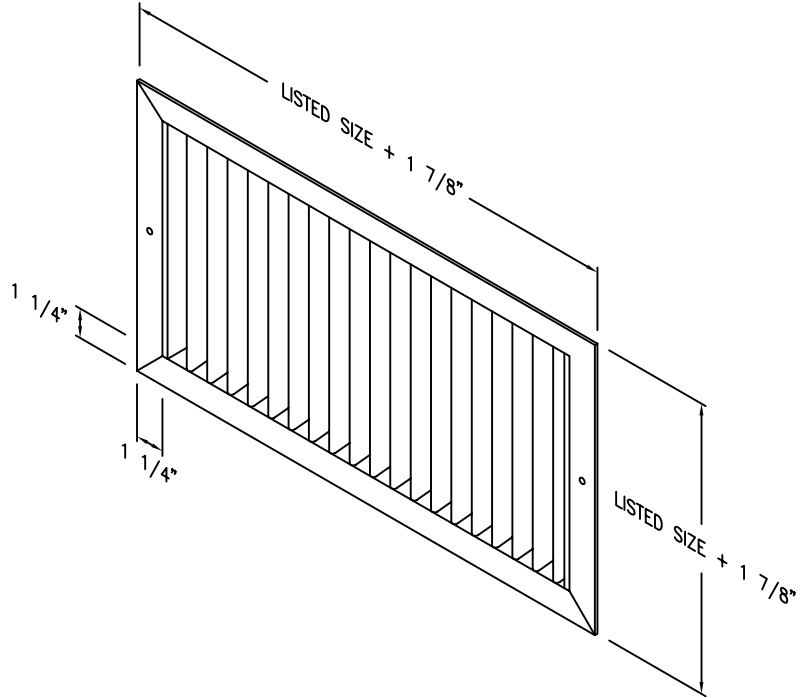

JOB NAME:
LOCATION:
ARCHITECT:
ENGINEER:
CONTRACTOR:
CONTACT GRILLE TECH INC. FOR ADDITIONAL INFORMATION OR WITH SPECIAL REQUIREMENTS. 5101 NW 36TH AVE MIAMI, FL 33142 PHONE: 305-537-0053 FAX: 305-577-0064 WEB: WWW.GRILLETECHINC.COM EMAIL: SALES@GRILLETECHINC.COM

V O R H

 ALUMINUM SINGLE DEFLECTOR SUPPLY
PRODUCT SPECIFICATIONS

NOTE: ALL DRAWINGS SUBJECT TO CHANGE WITHOUT PRIOR NOTICE.

DRAWN BY: AF	DATE: 12/20/07	SCALE: NOT TO SCALE	DRAWING NO. SG101-A
CHECKED BY: IG	DATE: 12/20/07	REVISION: IG	