

STANDARD CONSTRUCTION

FRAME:

COMPLETE MOLDED R6 INSULATED BACK MOUNTED ON 23-3/4" X 23-3/4" ALUMINUM PANEL.

FEATURES:

SUPERIOR SOUND ABSORPTION.
 LIGHT WEIGHT - EASILY SUSPENDED.
 CONDENSATION FREE OPERATION.
 45° FIXED BLADE CORE FOR SIGHT-PROOF APPEARANCE.
 FILTER MAY BE REMOVED FROM THE FACE WITHOUT THE USE OF SPECIAL TOOLS.
 SURFACE MOUNT, TEE-BAR LAY-IN, AND TEE-BAR PANEL FRAMES.
 THE MOLDED BACK IS EASILY CUT WITH A POCKET KNIFE AND THE CENTER CONNECTION PROVIDES A VERY UNIFORM, WIDELY DISPERSED AIR FLOW.

FINISH:

SKY-WHITE (STANDARD)

AXALTA SKY-WHITE 100% POLYESTER POWDER COATING GIVES AN ATTRACTIVE BRIGHT WHITE FINISH AND PROVIDES ADDITIONAL PROTECTION FROM AGING AND WEAR.

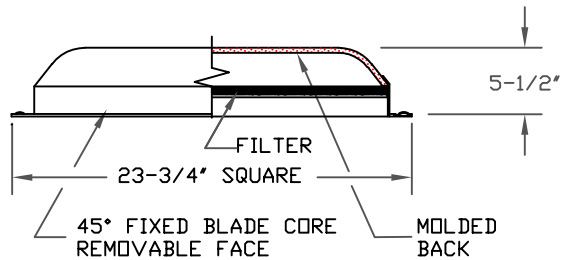
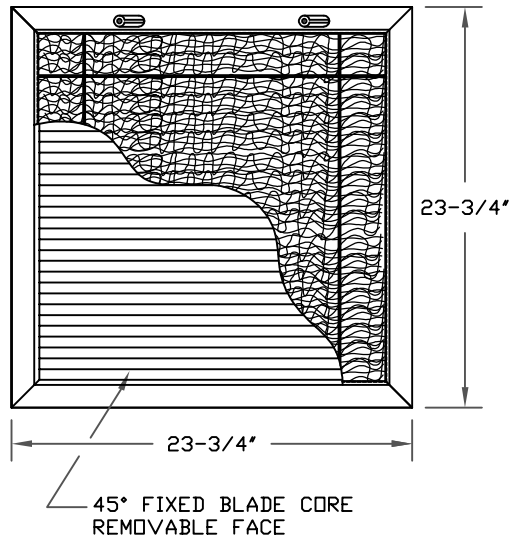

REAR VIEW

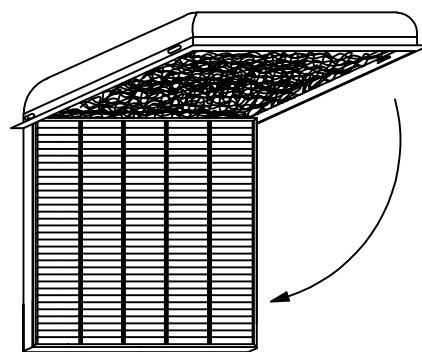
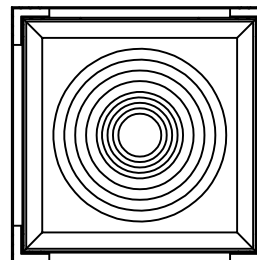

JOB NAME:
LOCATION:
ARCHITECT:
ENGINEER:
CONTRACTOR:
CONTACT GRILLE TECH INC. FOR ADDITIONAL INFORMATION OR WITH SPECIAL REQUIREMENTS.
5101 NW 36TH AVE MIAMI, FL 33142 PHONE: 305-537-0053 FAX: 305-537-0064
WEB: WWW.GRILLETECHINC.COM EMAIL: SALES@GRILLETECHINC.COM

MODEL RAFTU
 RETURN T-BAR WITH FILTER

DRAWN BY: MR	DATE: 6/20/17	SCALE: NOT TO SCALE	DRAWING NO.
CHECKED BY: IG	DATE: 6/30/17	REVISION: 6/20/17	RAFTU