

STANDARD CONSTRUCTION
FRAME:

6063T5 EXTRUDED ALUMINUM.
NOMINAL WALL THICKNESS OF 0.045"

FEATURES:

EXTRUDED ALUMINUM PROVIDES SUPERIOR DURABILITY AND CORROSION RESISTANCE. THE SMA MAKES IT POSSIBLE FOR LAY-IN TYPE DIFFUSERS (BORDER TYPE 6) TO BE INSTALLED IN SURFACE MOUNTING APPLICATIONS (BORDER TYPE 1).
FOUR MOUNTING CLIPS WITH SCREWS INCLUDED WITH EACH FRAME.
CAN BE USED IN BOTH PLASTER AND SHEET ROCK CEILINGS.
VARIOUS MOUNTING METHODS ALLOWS FOR EASY INSTALLATION IN DIFFERENT MOUNTING SITUATIONS.

FINISH:

SKY-WHITE (STANDARD)

AXALTA SKY-WHITE 100% POLYESTER POWDER COATING GIVES AN ATTRACTIVE FINISH AND PROVIDES ADDITIONAL PROTECTION FROM AGING AND WEAR.

STANDARD SIZES:

CEILING MODULE	RECOMMENDED CEILING OPENING	
	A	B
12" X 12"	12 1/2"	12 1/2"
24" X 12"	24 1/2"	12 1/2"
24" X 24"	24 1/2"	24 1/2"
36" X 24"	36 1/2"	24 1/2"
36" X 36"	36 1/2"	36 1/2"
48" X 24"	48 1/2"	24 1/2"
48" X 48"	48 1/2"	48 1/2"

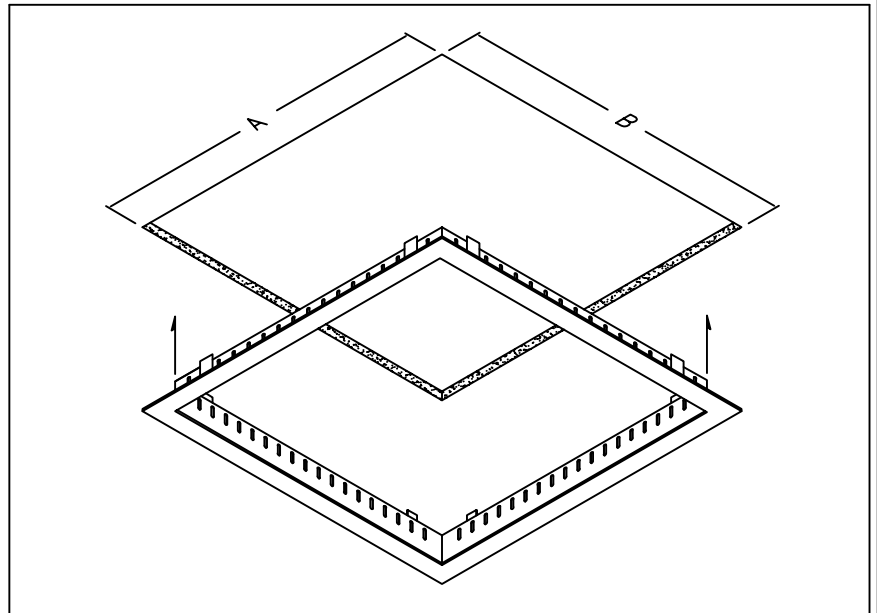
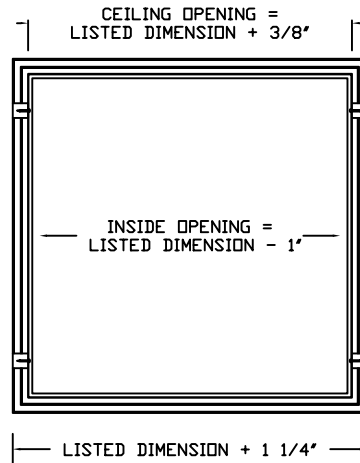

JOB NAME:
LOCATION:
ARCHITECT:
ENGINEER:
CONTRACTOR:
<p>CONTACT GRILLE TECH INC. FOR ADDITIONAL INFORMATION OR WITH SPECIAL REQUIREMENTS.</p> <p>5101 NW 36TH AVE MIAMI, FL 33142 PHONE: 305-537-0053 FAX: 305-537-0064</p> <p>WEB: WWW.GRILLETECHINC.COM EMAIL: SALES@GRILLETECHINC.COM</p>

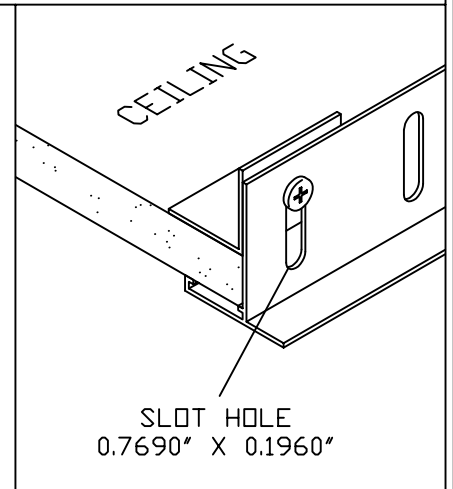
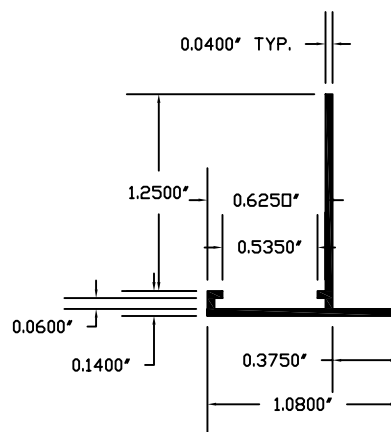
MODEL SMA
MOUNTING FRAME

DRAWN BY:	MR	DATE:	6/15/17	SCALE:	NOT TO SCALE
CHECKED BY:	IG	DATE:	6/31/17	REVISION:	6/15/17

 DRAWING NO.
SMA