

**STANDARD CONSTRUCTION**
**FRAME:**

3003H14 ROLL FORMED ALUMINUM.  
NOMINAL WALL THICKNESS OF 0.032"

**BLADES:**

3003H14 ROLL FORMED ALUMINUM.  
NOMINAL WALL THICKNESS OF 0.018"  
TEAR-DROP SHAPED AND ARE SPACED 3/4" ON  
CENTER.  
EACH BLADE INDIVIDUALLY ADJUSTABLE WITHOUT  
NEED FOR TOOLS.  
MODEL H: HORIZONTAL BLADES  
MODEL V: VERTICAL BLADES

**GASKET:**

RUBBER GASKET IN COMPLIANCE WITH FLORIDA  
STATE BUILDING CODE.

**DAMPER:**

OPPOSED BLADE DAMPER IS EASILY ADJUSTED  
THROUGH FACE.

**FINISH:**

SKY-WHITE (STANDARD)  
MILL FINISH (OPTIONAL)

AXALTA SKY-WHITE 100% POLYESTER POWDER  
COATING GIVES AN ATTRACTIVE BRIGHT WHITE  
FINISH AND PROVIDES ADDITIONAL PROTECTION  
FROM AGING AND WEAR.

**STANDARD SIZES:**

4" X 4" MIN  
24" X 12" MAX

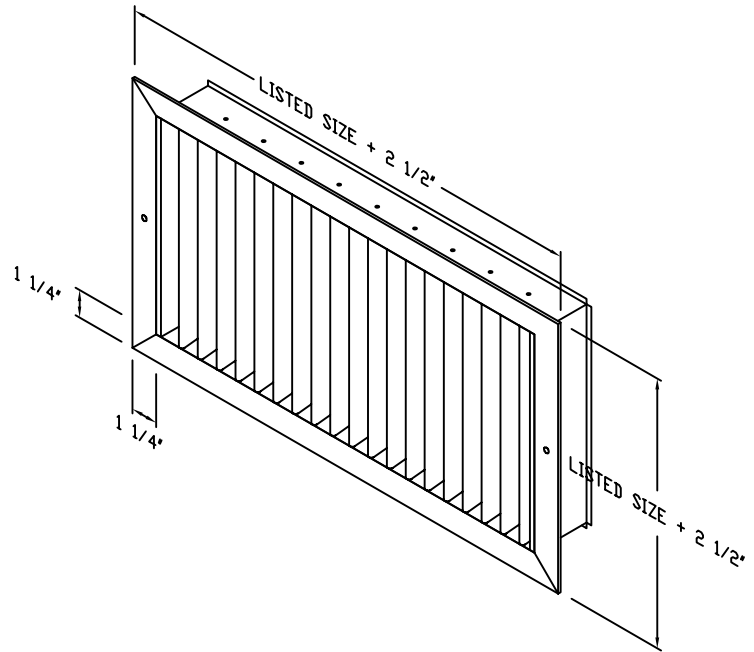
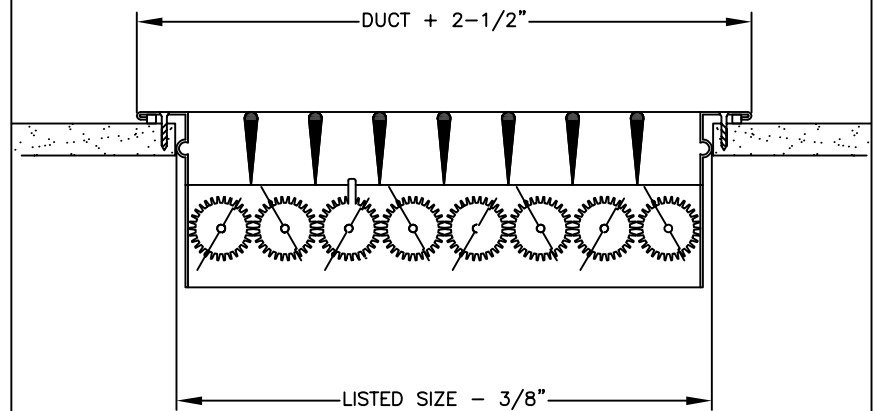
**SURFACE MOUNT**

JOB NAME:
LOCATION:
ARCHITECT:
ENGINEER:
CONTRACTOR:
<p>CONTACT GRILLE TECH INC. FOR ADDITIONAL INFORMATION OR WITH SPECIAL REQUIREMENTS.</p> <p>5101 NW 36TH AVE MIAMI, FL 33142 PHONE: 305-537-0053 FAX: 305-537-0064</p> <p>WEB: WWW.GRILLETECHINC.COM EMAIL: SALES@GRILLETECHINC.COM</p>

**VOB AND HOB**

ALUMINUM SINGLE DEFLECTION SUPPLY  
VERTICAL OR HORIZONTAL  
WITH OPPOSED BLADE DAMPER

NOTE: ALL DRAWINGS SUBJECT TO CHANGE WITHOUT PRIOR NOTICE.

DRAWN BY:	MR	DATE:	12/17/18	SCALE:	NOT TO SCALE
CHECKED BY:	IG	DATE:	12/17/18	REVISION:	12/17/18

DRAWING NO.  
**VOB/HOB**